

NOTES

GENERAL

1. All dimensions are in millimetres, unless otherwise noted.
2. Do not scale these drawings. Use figured dimensions.
3. The Contractor shall check, verify on site and be responsible for the correctness of all dimensions shown on the drawings and discrepancies shall be reported immediately to the Project Manager before any work proceeds.
4. These drawings shall be read in conjunction with all other drawings and specifications and with such other written instructions as may be issued during the course of construction. All discrepancies shall be reported immediately for decision before proceeding with the project.
5. Any potential interference with existing trees is to be identified by the Contractor and reported to the Project Manager and Council's Arborist prior to commencement of construction.
6. All workmanship and materials shall be in accordance with the requirements of the Landscape Policy and Construction Standards, Standards Australia Codes and the by-laws and ordinances of the relevant authorities.
7. During construction any structure and neighbouring structures shall be maintained in a stable condition, ensuring no parts are overstressed.
8. The contractor is to confirm the location and depth of services within the construction limits prior to commencement of construction. Services to be noted on As Constructed drawings.
9. The Contractor shall rectify any damage to existing hard and soft infrastructure and/or services, caused through carrying out the works, at the Contractor's expense.
10. It is the contractors responsibility to ensure that the project is carried out in accordance with the drawings and specifications.
11. Material choices are to be determined on the grounds of sustainability, low maintenance, vandal resistance, product availability and suitability to the climatic conditions. Materials are to be locally sourced.
12. Consider access and inclusion for all where appropriate, to Australian Standards.

CITY PLAN REFERENCES

Part 9.3.3	Landscape Code
SC6.4.12.1	Policy Intent
SC6.4.23	Construction Management
SC6.4.23.1	Construction (Protection of Trees and Vegetation)
SC6.4.10.3	Construction Standards
SC6.4.18	Concrete Works
SC6.4.6.17	Control of Traffic

COMPACTION

1. Compact sub-base and deco material separately not less than 95% maximum dry density as determined by the modified compaction test as defined in AS1289 for the upper 150mm. Avoid compaction around the base of existing and proposed trees.

SUB-BASE PREPARATION

1. Ensure sub-base profile forms the required drainage falls when the surface is laid.

SURFACE CONSTRUCTION

1. The following steps are suggested and will need to be repeated to achieve the finished surface level (FSL):
 - Place and rake evenly approximately 30mm of Decomposed granite material.
 - Add soil stabiliser Dustac or Soiltac (or approved equivalent) at a rate recommended by manufacturer, alternatively mix through cement at 5-10% ratio with a concrete mixer. Ensure the cement is evenly mixed to avoid patches of cement at the surface.
 - Moisten the material and compact using vibrating roller. The roller should not weigh more than 30kg.
2. The finished surface shall be free from stones exceeding 20mm in diameter and shall remain free of ruts, subsidence and lack of cohesion.
3. If at time of construction, the sub-grade strength is such that it is penetrating / infiltrating the Class 2 gravel layer during compaction, a type 3 geotextile is to be placed between the gravel and the sub-grade.

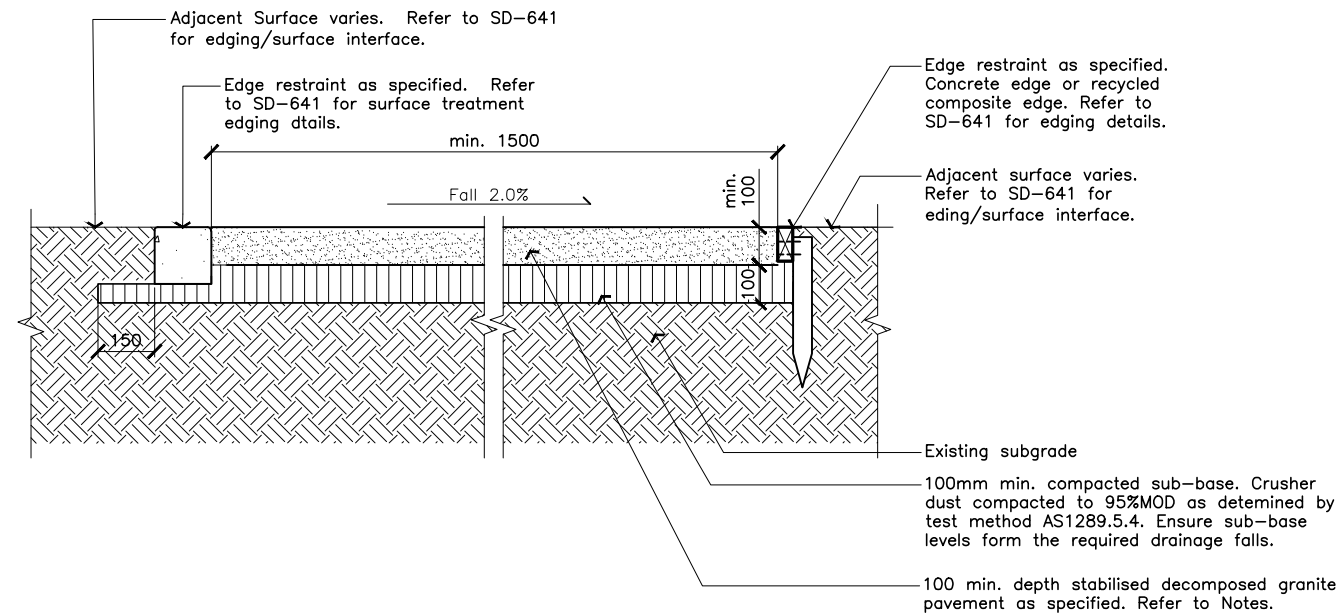

STABILISED DECOMPOSED GRANITE PATH DETAIL

NOTES :
REFERENCE DRAWINGS
SD-641 - Surface Treatment Edging

No.	DATE	DESCRIPTION	AP'D
C	28/03/2024	CITY PLAN REFERENCE UPDATE	PM
B	04/03/2024	UPDATED NOTES	
A	23/10/2020	ORIGINAL ISSUE	
REVISIONS			

Full Size A1

DRAWN: DESIGN OFFICE

CHECKED: HB

Senior Open Space Planner Approved: *Hani El Sitar*

Date: Jun 17, 2024

Team Manager EAIP Approved: *Zdenka Vrazek*

Date: Jun 17, 2024



Ph: (07) 4727 9000
www.townsville.qld.gov.au

**SURFACE TREATMENT
DECOMPOSED GRANITE PATH**

**STANDARD
DRAWING**

OPEN SPACE

SD-644

C